

# Eaton SB58901EAL

Catalog Number: SB58901EAL

Eaton B-Line series open frame racks, Aluminum, 3/8"-16 mounting hardware, (2) RMUs of mounting space, Aluminum - brushed, Two-post network equipment rack guard rail, Used to protect 19" rack mounted equipment

## General specifications

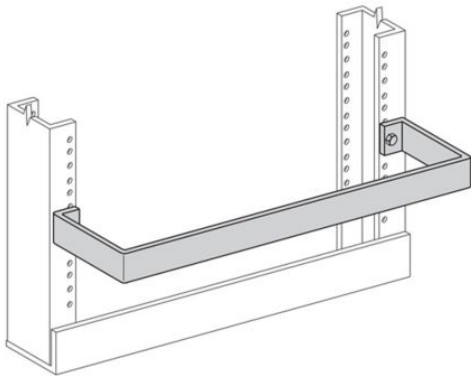

Product Name	Catalog Number
Eaton B-Line series open frame racks	SB58901EAL
UPC	Product Length/Depth
799038029854	9.5 in
Product Height	Product Width
2 in	19 in
Product Weight	Certifications
2 lb	Not Applicable

## Product specifications

### Special features

(2) RMUs of mounting space

### Model

Two-post network equipment rack guard rail

### Material

Aluminum

### Finish

Brushed aluminum

## Resources

### Brochures

[RCM and RCM+ brochure](#)

### Specifications and datasheets

[Eaton Specification Sheet - SB58901EAL](#)



Eaton Corporation plc  
Eaton House  
30 Pembroke Road  
Dublin 4, Ireland  
Eaton.com  
© 2023 Eaton. All Rights Reserved.

Eaton is a registered trademark.

All other trademarks are property of their respective owners.



[Eaton.com/socialmedia](https://www.eaton.com/socialmedia)